

# UL SERIES

## PUSH AROUND MAST LIFTS



- Robust push-around mast lifts
- Patented Girder Lock mast design for stable working up to 40ft.
- Compact dimensions
- Passes through a standard doorway
- Easy loader system for flatbed vehicle transport

 **snorkel**  
[www.snorkellifts.com](http://www.snorkellifts.com)

# UL Series

## PUSH AROUND MAST LIFTS

DIMENSIONS	UL25	UL32	UL40
Max. working height	30 ft 11 in	37 ft 9 in	46 ft
Max. platform height (A)	24 ft 11 in	31 ft 9 in	40 ft
Platform length	22 in	22 in	22 in
Platform width	26 in	26 in	26 in
Stabilizer footprint (B x C)	4 ft 2 in x 4 ft 7 in	6 ft 7 in x 6 ft 5 in	7 ft 6 in x 7 ft 4 in
Overall width (F)	29 in	29 in	29 in
Overall length (D)	4 ft 1 in	4 ft 4 in	4 ft 4 in
Stowed height (E)	6 ft 6 in	8 ft 3 in	9 ft 6 in
Tilt back length (H)	8 ft 8 in	8 ft 8 in	10 ft
Tilt back height (G)	6 ft 2 in	5 ft 11 in	6 ft 6 in

PERFORMANCE			
Platform capacity (SWL)	350 lbs	300 lbs	300 lbs
Raise/lower time	43/23 seconds	57/26 seconds	60/40 seconds
Wheels	9 in x 2.5 in rear, 6 in castors front		
Controls	push button		
Wall access (Distance from front of platform to wall)	4 in	14 in	20 in

POWER	
Power source (AC)	120/220V AC 50HZ
Power source (DC)	1 X 12V 105AH battery

WEIGHT			
Weight (AC)	769 lbs	919 lbs	990 lbs
Weight (DC)	809 lbs	959 lbs	1,030 lbs

### STABILIZER FOOTPRINT

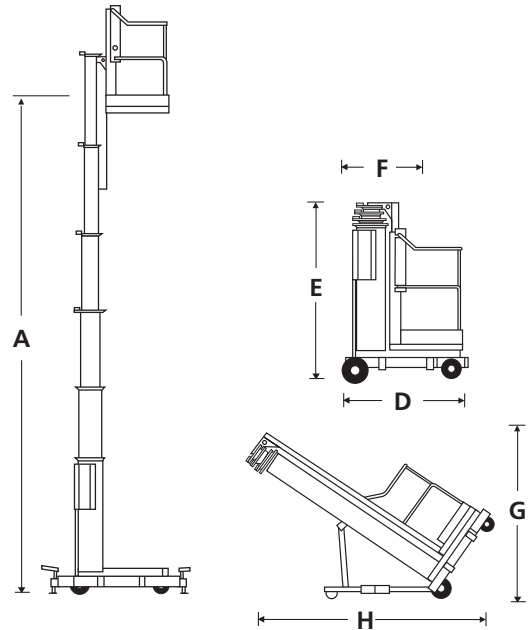
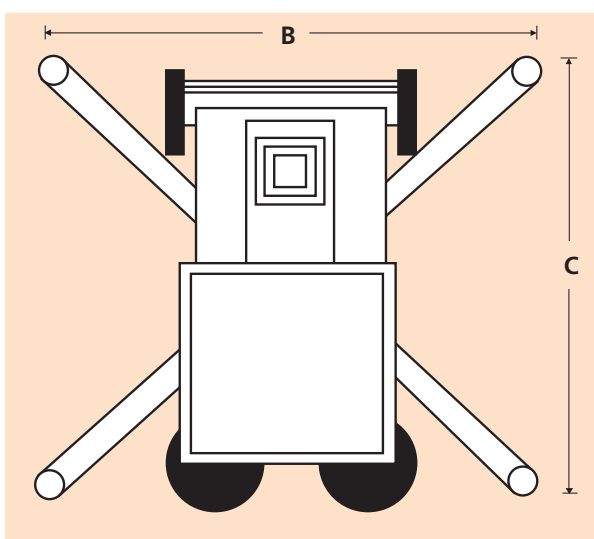

### STANDARD FEATURES

- Tilt-back mechanism
- Stabilizer interlock indicators
- Integrated battery charger (DC only)
- Power line to platform
- Non-marking wheels & castors
- ANSI compliant

### OPTIONS

- Special paint colors
- Tool tray
- Canvas bag for fluorescent tubes
- Laser locator
- Environmental green oil
- CSA compliant

**snorkel** [www.snorkellifts.com](http://www.snorkellifts.com)

P.O. Box 1160  
 St. Joseph, MO 64502-1160, USA  
 Tel: 1 (785) 989-3000  
 Toll-free: 1 (800) 255-0317  
 Sales Fax: 1 (785) 989-3070  
 Parts Fax: 1 (785) 989-3077